

FLEX **POST**[®]

GSA Contract Holder

2019 CATALOG

Impact Resistant Solutions for Bollards & Sign Posts

The Perfect Break-Fix Solution



616-928-0829

www.flexpostinc.com • sales@flexpost.net

2236 112th Ave, Suite 80, Holland, MI 49424

Table of Contents

PRODUCT OVERVIEWS

Standard Flexible Sign Post	4
Heavy-Duty Flexible Sign Post	5
Standard Flexible Bollard	6
Heavy-Duty Flexible Bollard	7
Standard Flexible Bollard with Post	8
Heavy-Duty Flexible Bollard with Post.....	9

EXPLODED VIEWS & PARTS LIST

Standard Flexible Sign Post	10
Heavy-Duty Flexible Sign Post	11
Standard Flexible Bollard	12
Heavy-Duty Flexible Bollard	13
Standard Flexible Bollard with Post	14
Heavy-Duty Flexible Bollard with Post.....	15
Standard Ground Flexible Sign Post	16
Post-Lite™	17

SM PRODUCT LINE

Flexpost-SM™ Product Line Overview	18
Flexpost-SM™ Delineator Paddle	19
Flexpost-SM™ Channelizer Post.....	20
Flexpost-SM™ Guide Post.....	21

Flexpost® Accessories	22-23
-----------------------------	-------

About Us

Our Mission:

To work closely with all our customers and take a consultative approach to their projects. We realize that our customers' parking lots are the first thing seen by their patrons and would like to keep them looking nice and in order without seeing bent sign posts and bollards. Our goal is to provide innovative, cost saving products designed to eliminate damage to parking lot posts, surfaces and vehicles. Across the world, the FlexPost's Family of Products has saved property owners hundreds of thousands of dollars by eliminating these costly damages to parking lots.

We are a philanthropic organization that helps our local community by supporting and employing disabled individuals in our operations and fulfillment process. Also, we exemplify continuous improvement through lean manufacturing principles to keep our promises to our customers by providing on-time solutions.



Our History:

FlexPost Inc. started in 2006 to help the owners of Rivertown Crossings Shopping Mall in Michigan. Their dilemma of replacing 20-30% of the rigid parking lot sign posts every year due to damage was all too common and expensive. To solve this problem, a flexible sign post was invented. FlexPost® are now being used all over the world!

All patented FlexPost® systems are constructed of carbon steel and manufactured in the USA and Canada. The FlexPost® family expanded when the FlexBollard™ system was introduced in 2008. These innovative units provide the flexibility of the standard FlexPost® with the rigid appearance of a concrete bollard.

The FlexPost-XL™ (heavy-duty) & FlexPost-SM™ (light-duty) were introduced in early 2017. These products are made of all-steel components and carry a lifetime replacement warranty for the base unit. As with any FlexPost® product, the FlexPost-XL™ minimizes vehicle and parking surface damage while withstanding the most extreme collisions imaginable. Also added in 2017, the FlexPost-SM™ line is lighter and smaller than typical FlexPost™ products. This product line includes sign posts, guideposts, and delineator paddles that offer the same 360° flexibility upon impact at a reduced price. The FlexPost-SM™ line is perfect for protecting areas with high pedestrian walking traffic.

Now with a presence in four countries, we are positioned to access and solve bent parking lot sign problems worldwide!

In 2018 FlexPost, Inc. became GSA certified. We commonly assist government entities, military bases, VA hospitals, and municipalities.



Standard Flexible Sign Post

STD-6'
STD-8'



Finished Height	Post Diameter
78"	1 5/8"
102"	1 5/8"
CUSTOM	1 5/8"

ANCHORING OPTIONS:



CONCRETE ASPHALT ADHESIVE GROUND

- Patented Torsion Spring
- Withstands Repeated Impacts
- Standard Manufacturer's Warranty
- ADA Compliant
- 1 5/8" Diameter Post
- Powder Coated Base
- Surface Mounted

* Sign Sold Separately *

- Perfect Break-Fix Solution
- Make Speedy Repairs to Broken Sign Posts
- Takes Minutes to Install
- No Special Tools Required
- Handles Standard Sized Signs
- Eliminates Damage to Parking Lot Surface

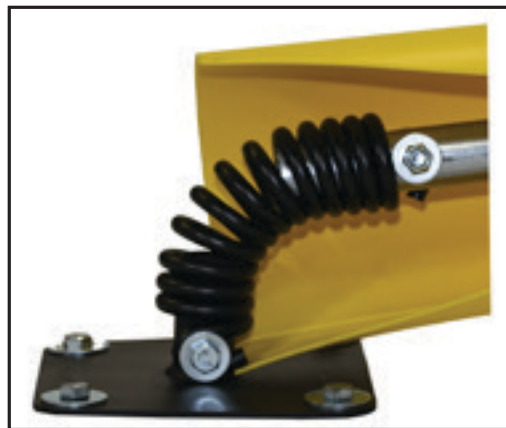

Heavy-Duty Flexible Sign Post

XL-6'
XL-8'
XL-9'

ANCHORING OPTIONS:



CONCRETE ASPHALT ADHESIVE

Finished Height	Post Diameter
78"	2 3/8"
102"	2 3/8"
108"	2 3/8"
CUSTOM	2 3/8"



* Sign Sold Separately *

- Perfect Break-Fix Solution
- Make Speedy Repairs to Broken Sign Posts
- Takes Minutes to Install & No Special Tools Required
- Handles Large Regulatory Sized Signs
- Eliminates Damage to Parking Lot Surface

- Concealed Spring Technology
- Withstands Extreme Impacts & High Winds
- Lifetime Guaranteed Base
- ADA Compliant
- 2 3/8" Diameter Post
- Galvanized Base
- Surface Mounted



OPTIONAL DETENT BRACKET KIT

Galvanized steel detent brackets designed to keep the post extra rigid and tamper proof until it is struck by a vehicle.





Standard Flexible Bollard

STD-B32
STD-B52
STD-B72

Finished Height Post Diameter Bollard Diameter

32"	1 5/8"	7"
52"	1 5/8"	7"
72"	1 5/8"	7"

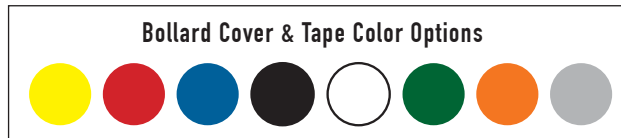
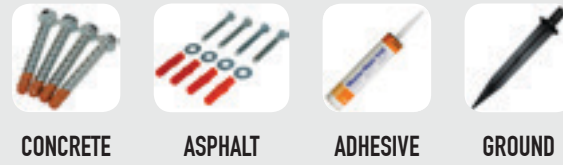
ANCHORING OPTIONS:



- Deters Vehicle Impact
- Rigid Bollard Appearance
- Patented Torsion Spring
- Withstands Repeated Impacts
- Standard Manufacturer's Warranty
- 1 5/8" Diameter Post
- Powder Coated Base
- Surface Mounted



ADA Sticker Available

- Eliminates Damage to Cars and Parking Lot Surfaces
- Takes Minutes to Install
- No Special Tools Required

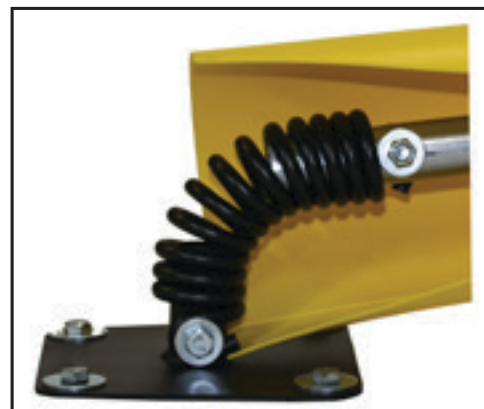

Heavy-Duty Flexible Bollard

XL-B32
XL-B52
XL-B72

Finished Height Post Diameter Bollard Diameter

32"	2 3/8"	7"
52"	2 3/8"	7"
72"	2 3/8"	7"

ANCHORING OPTIONS:

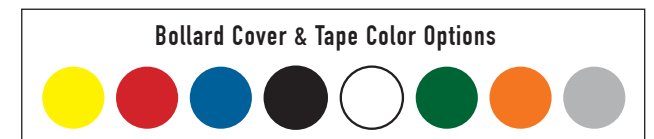

- Deters Vehicle Impact
- Rigid Bollard Appearance
- Concealed Spring Technology
- Withstands Extreme Impacts & High Winds
- Lifetime Guaranteed Base
- 2 3/8" Diameter Post
- Galvanized Base
- Surface Mounted

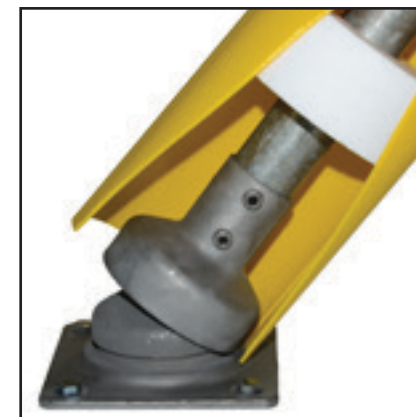

- Eliminates Damage to Cars and Parking Lot Surfaces
- Takes Minutes to Install
- No Special Tools Required
- Indestructible Base

Standard Flexible Bollard with Post

STD-B52/8

ANCHORING OPTIONS:

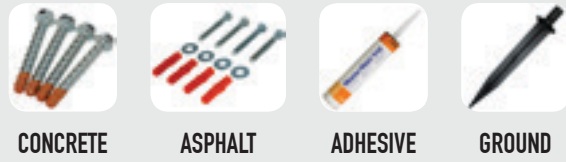

Bollard Cover & Tape Color Options



- Deters Vehicle Impact
- ADA Compliant
- Rigid Bollard Appearance
- Patented Torsion Spring
- Suited for Standard Sized Sign
- Withstands Repeated Impacts
- Standard Manufacturer's Warranty
- 1 5/8" Diameter Post
- Powder Coated Base
- Surface Mounted

Finished Height	Post Diameter	Bollard Diameter
102"	1 5/8"	7"



* Sign Sold Separately *

- Perfect Break-Fix Solution
- Make Speedy Repairs to Broken Sign Posts
- Takes Minutes to Install
- No Special Tools Required
- Eliminates Damage to Cars and Parking Lot Surfaces



XL-B52/8

Heavy-Duty Flexible Bollard with Post

Finished Height	Post Diameter	Bollard Diameter
78"	2 3/8"	7"
102"	2 3/8"	7"
108"	2 3/8"	7"

- Deters Vehicle Impact
- ADA Compliant
- Rigid Bollard Appearance
- Concealed Spring Technology
- Suited for Large Regulatory Signs & High Winds
- Lifetime Guaranteed Base
- 2 3/8" Diameter Post
- Galvanized Base
- Surface Mounted



* Sign Sold Separately *

ANCHORING OPTIONS:

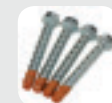

CONCRETE



ASPHALT



ADHESIVE

Bollard Cover & Tape Color Options



- Perfect Break-Fix Solution
- Make Speedy Repairs to Broken Sign Posts
- Takes Minutes to Install
- No Special Tools Required
- Eliminates Damage to Cars and Parking Lot Surfaces
- Indestructible Base



Standard Flexible Sign Post

STD-6'
STD-8'



PARTS LIST

#	Quantity	Part Number	Dimensions & Description
1	2	37030	1/2" - 13 Lock Nut - Zinc
2	1	RE-SK	Patented Torsion Spring
3	1	RE-#P	Choice of 6' or 8' x 1 5/8" Post - .055" Wall
4	1	RE-BP	9" x 9" Square Base Plate
5	4	33012	1/2" x 1.375" Flat Washer - Zinc
6	2	13824	1/2" - 13 x 3" Tap Bolt - Zinc
7	1	RE-SB	Double Sided Sign Bracket Kit (Includes 2 Sign Brackets, 4 Set Screws, and 4 Lock Nuts)

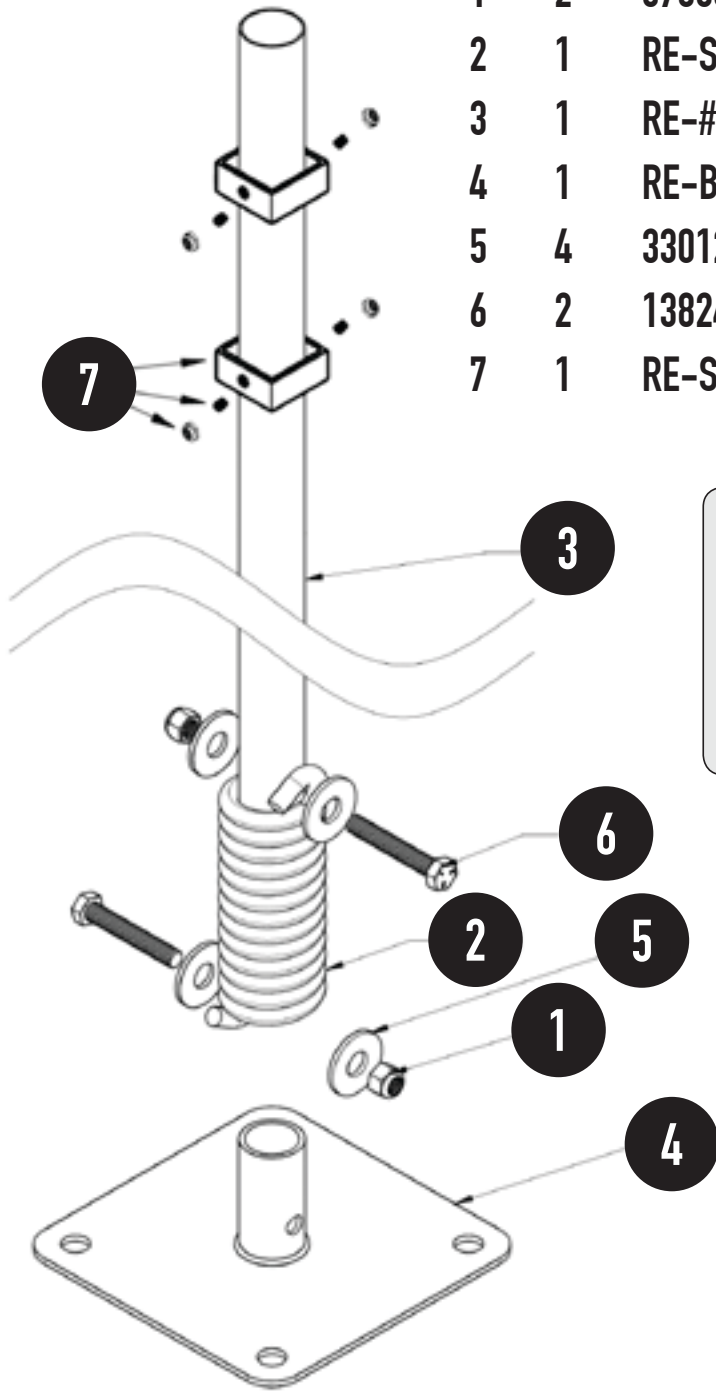

ANCHORING OPTIONS:



* Sign Sold Separately *

Heavy-Duty Flexible Sign Post

XL-6'
XL-8'
XL-9'



PARTS LIST

#	Quantity	Part Number	Dimensions & Description
1	1	RE-SB	Double Sided Sign Bracket Kit (Includes 2 Sign Brackets, 4 Set Screws, and 4 Lock Nuts)
2	2	1139864	5/16" - 18 x 1/2" Set Screw
3	1	A-XL-SK	8" x 8" Base & Spring Assembly
4	1	RE-XL-#P	2 3/8" Diameter Galv. Post - .055" Wall
5	1	1131832	3/4" Self Tapping Set Screw

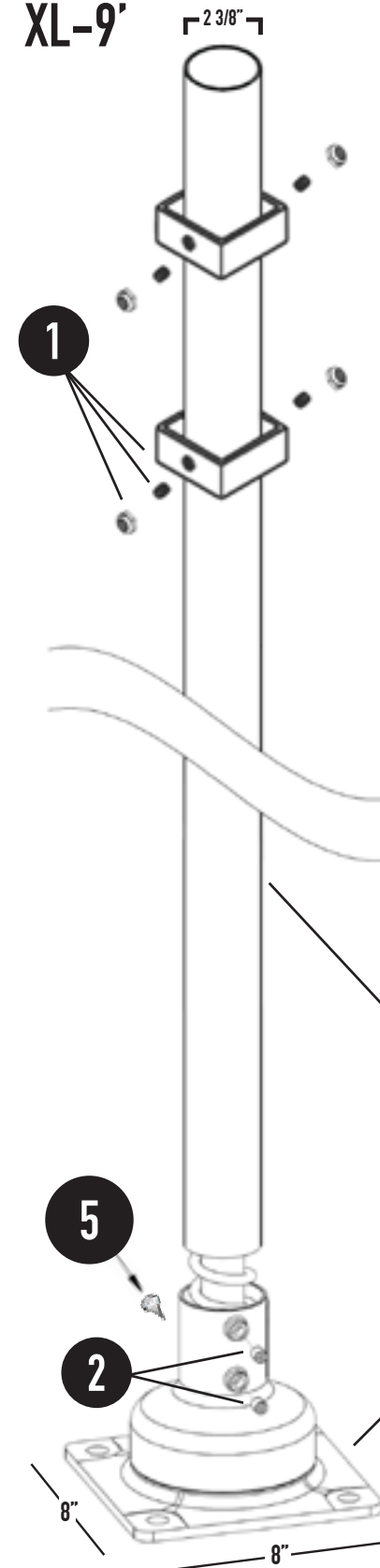

ANCHORING OPTIONS:



4 CHOICE OF POST

POST LENGTH	ASSEMBLED HEIGHT
75"	78"
99"	102"
105"	108"



Standard Flexible Bollard

STD-B32
STD-B52
STD-B72

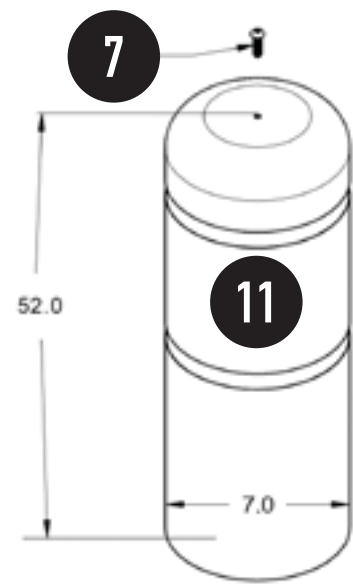

PARTS LIST

#	Quantity	Part Number	Dimensions & Description
1	2	37030	1/2"-13 Lock Nut - Zinc
2	1	RE-SK	Patented Torsion Spring
3	1	RE-BP	9" x 9" Square Base Plate
4	4	33012	1/2" x 1.375" Flat Washer - Zinc
5	2	13824	1/2"-13 x 3" Tap Bolt - Zinc
6	1	11253669	10 x 1/2" Self Tapping Screw
7	1	73780	5/16"-18 x 1" Cap Screw
8	1	RE-CP	Anti-Rotate Bollard Cap
9	1	RE-FR-7	7" Foam Spacer Ring
10	1	RE-47P	1 5/8" x 47.5" Galv. Steel Post - .055"
11	1	RE-BC52	52" x 7" Bollard Cover

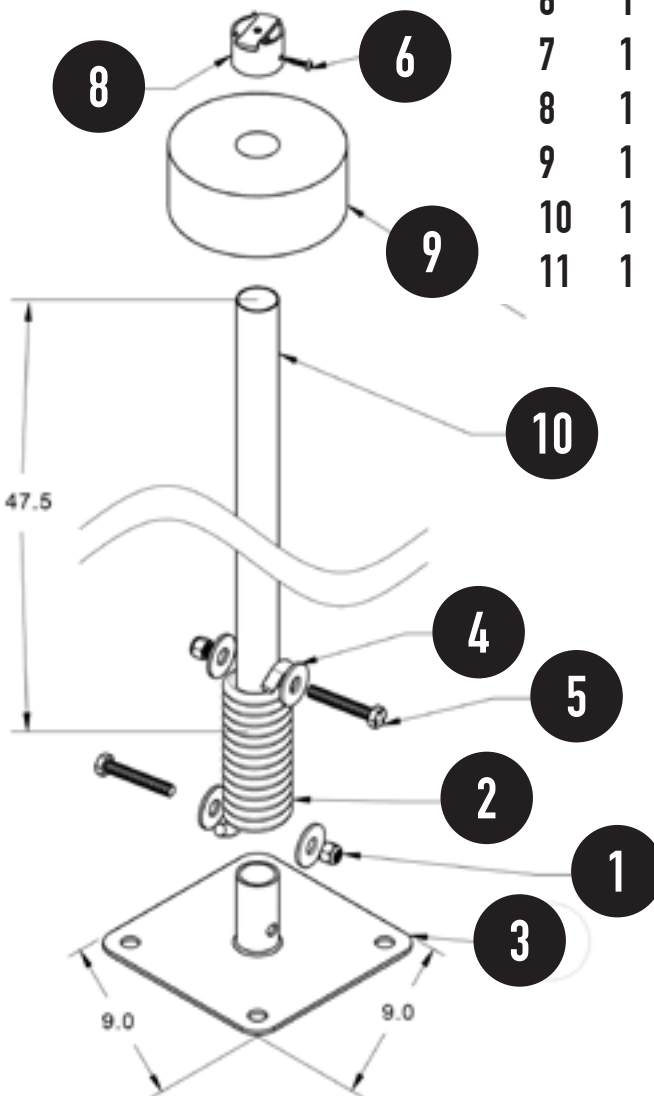

ANCHORING

CHOICE OF:



CONCRETE



ASPHALT



ADHESIVE



GROUND

Heavy-Duty Flexible Bollard

XL-B32
XL-B52
XL-B72

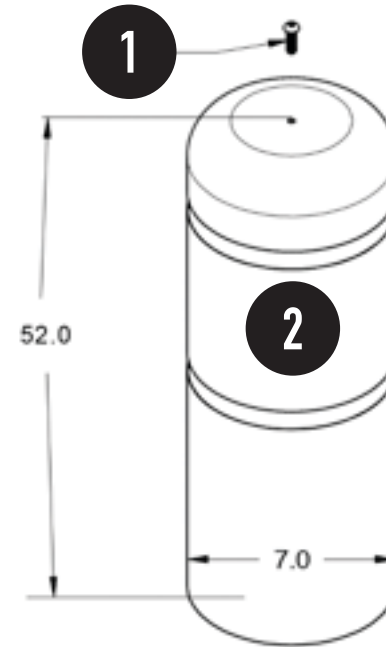

PARTS LIST

#	Quantity	Part Number	Dimensions & Description
1	1	73780	5/16" - 18" x 1" Hex Drive Cap Screw
2	1	RE-BC52	52" x 7" Bollard Cover
3	1	RE-XL-BC	Anti-Rotate Bollard Cap Kit
4	2	RE-FR-7	7" Foam Spacer Ring
5	1	RE-XL-47P	48.5" x 2 3/8" Steel Post - .055" Wall
6	1	A-XL-SK	8" x 8" Base & Spring Assembly
7	2	1139864	5/16" - 18 x 1/2" Set Screw
8	1	1131832	3/4" Self Tapping Set Screw

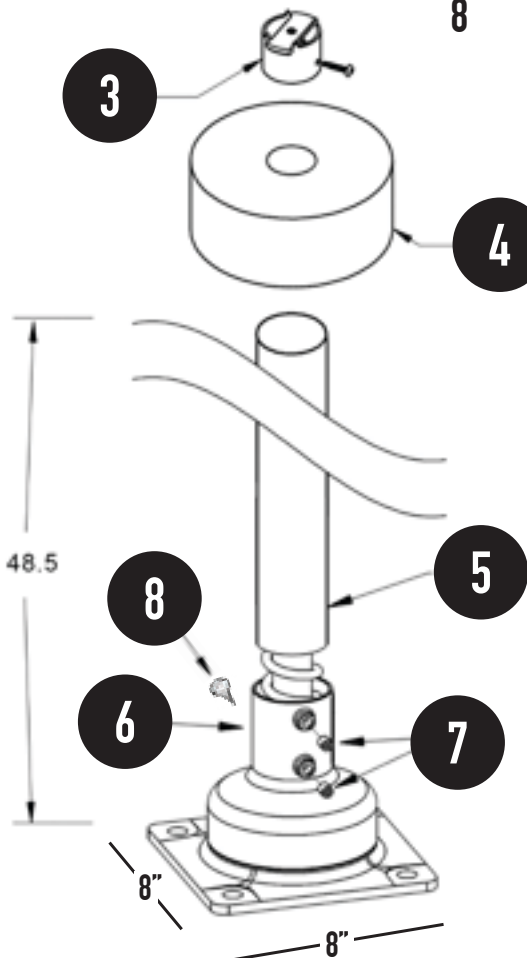

ANCHORING OPTIONS:

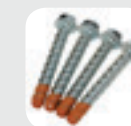

CONCRETE

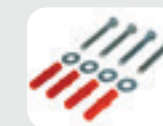

ASPHALT



ADHESIVE



Standard Flexible Bollard with Post

STD-B52/8

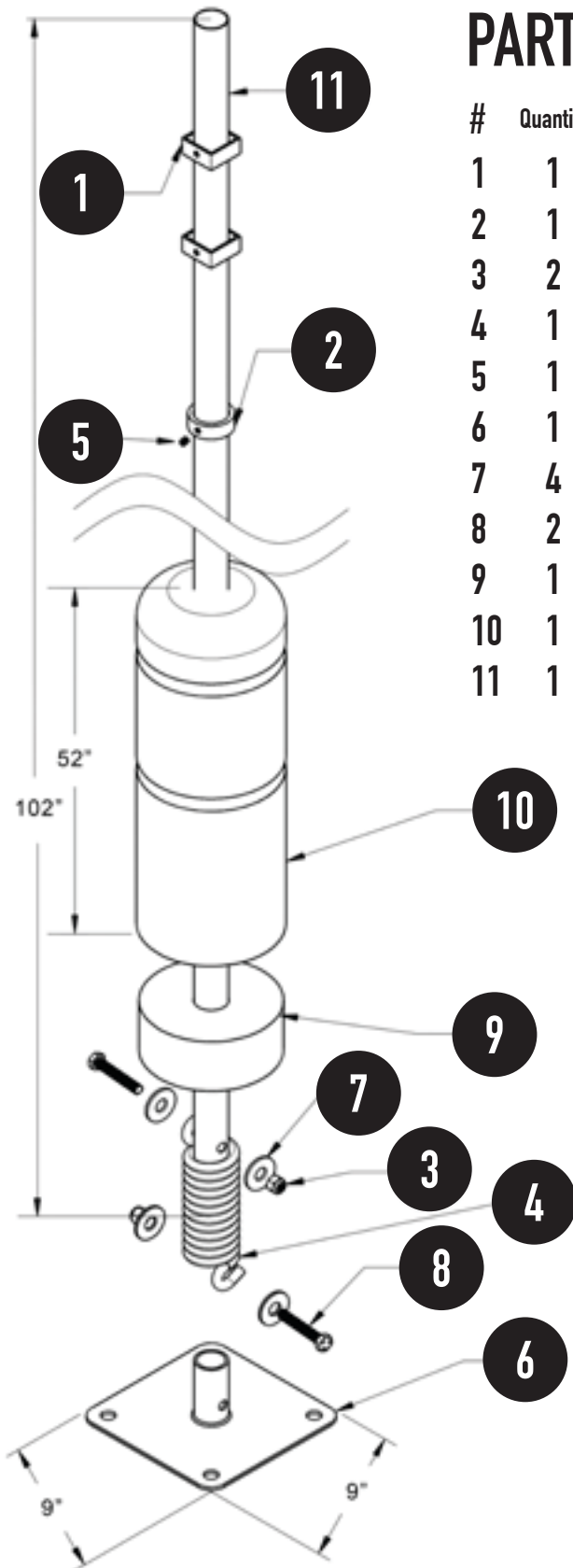

PARTS LIST

#	Quantity	Part Number	Dimensions & Description
1	1	RE-SB	Double Sided Sign Bracket Kit
2	1	RE-CK225	2.25" Round Collar Ring
3	2	37030	1/2"-13 Lock Nut - Zinc
4	1	RE-SK	Patented Torsion Spring
5	1	73278	5/16"-18 x 3/8" Set Screw
6	1	RE-BP	9"x9" Square Base Plate
7	4	33012	1/2" x 1.375" Flat Washer - Zinc
8	2	13824	1/2"-13 x 3" Tap Bolt - Zinc
9	1	RE-FR-7	7" Foam Spacer Ring
10	1	RE-BC52	52" x 7" Bollard Cover
11	1	RE-8P	1 5/8" x 8' Galv. Steel Post - .055 (6' Pole Available Upon Request)



ANCHORING CHOICE OF:



CONCRETE



ASPHALT



ADHESIVE



GROUND

www.flexpostinc.com • sales@flexpost.net • 616-928-0829

XL-B52/8
XL-B52/9

Heavy-Duty Flexible Bollard with Post

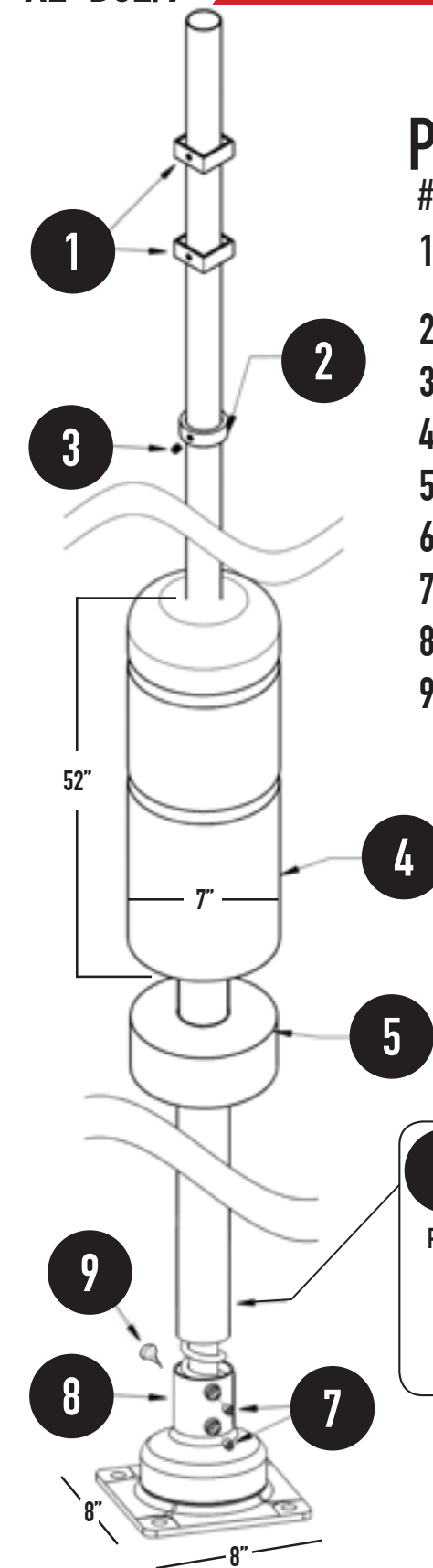

PARTS LIST

#	Quantity	Part Number	Dimensions & Description
1	1	RE-SB	Double Sided Sign Bracket Kit (Includes 2 Sign Brackets, 4 Set Screws, and 4 Lock Nuts)
2	1	RE-CK3	3" Round Collar Ring
3	1	73278	Set Screw for Collar
4	1	RE-BC52	52" x 7" Bollard Cover
5	2	RE-FR-7	7" Foam Spacer Ring
6	1	RE-XL-#P	2 3/8" Diameter Galv. Post - .055" Wall
7	2	1139864	5/16" - 18 x 1/2" Set Screw
8	1	A-XL-SK	8" x 8" Base & Spring Assembly
9	1	1131832	3/4" Self Tapping Set Screw

ANCHORING OPTIONS:

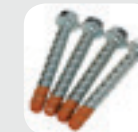

CONCRETE



ASPHALT



ADHESIVE

CHOICE OF POST

POST LENGTH	ASSEMBLED HEIGHT
75"	78"
99"	102"
105"	108"



www.flexpostinc.com • sales@flexpost.net • 616-928-0829

Standard Ground Flexible Sign Post

STD-G



PARTS LIST

#	Quantity	Part Number	Dimensions & Description
1	1	RE-GS	21" Ground Spike, Powder Coated
2	2	37030	1/2" - 13 Lock Nut - Zinc
3	1	RE-SK	Patented Torsion Spring
4	1	RE-6P	1 5/8" x 6' Galv. Steel Post - .055"
5	4	33012	1/2" x 1.375" Flat Washer - Zinc
6	2	13824	1/2" - 13 x 3" Tap Bolt - Zinc
7	1	RE-SB	Double Sided Sign Bracket Kit (Includes 2 Sign Brackets, 4 Set Screws, and 4 Lock Nuts)

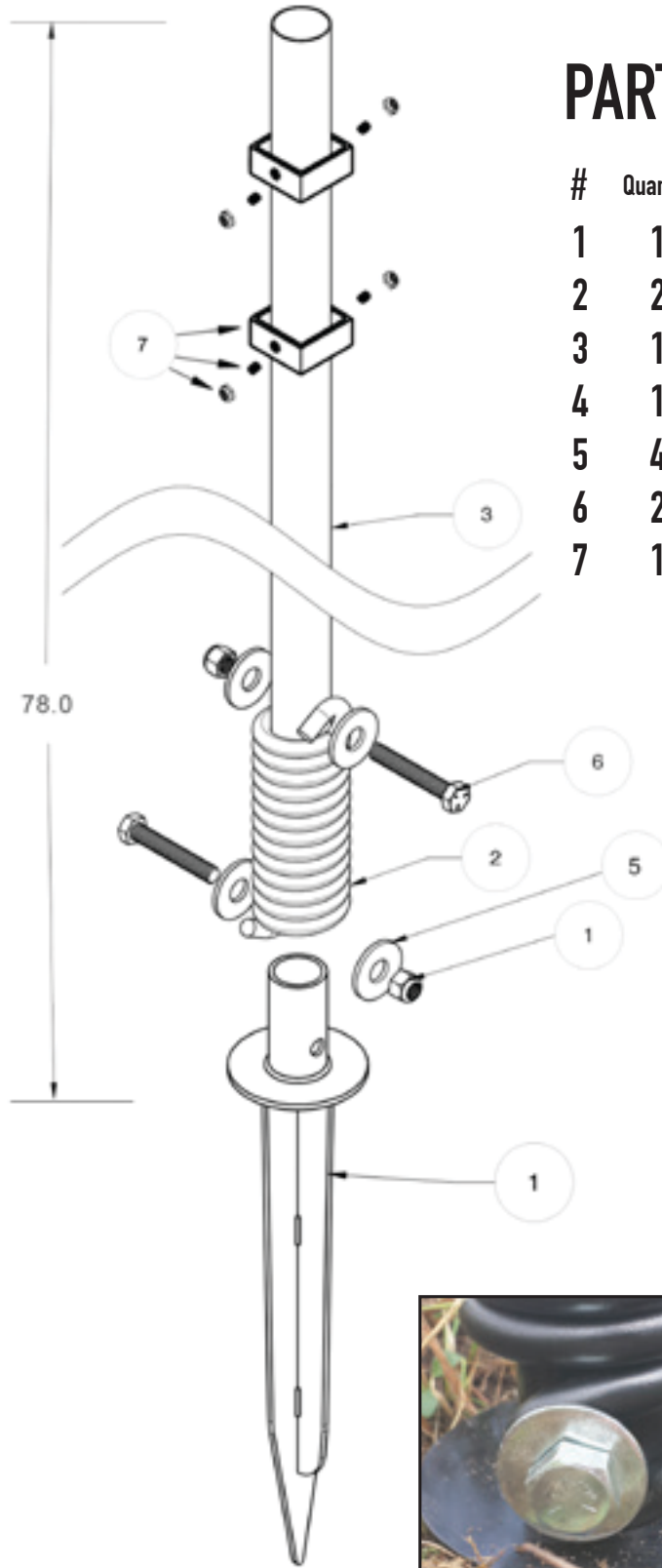

A-PL-STD
A-PL-XL

Post-Lite™



ASSEMBLY GUIDE
& SPEC. SHEET

- Solar Panel: Poly-Silicon 6v 120 mA
- Solar Charge Time: 8 hours
- Working Temperature: -5° to 120° F
- Rainproof & Durable
- Brightness: 60 lumens
- Rechargeable and Replaceable Battery (AA)



- ### ASSEMBLY GUIDE
1. Remove black top
 2. Switch unit to the on position
 3. Slide the black top back into the clear bottom
 4. Place tape (not provided) over the three connections
 5. Put unit over post
 6. Drill 2 tap screws (provided) through holes in the black cap and into the post to secure.

On/Off Switch

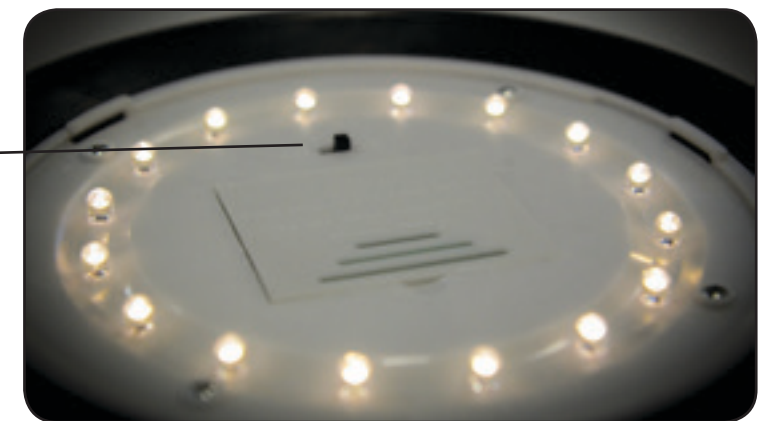

16 LED Solar Charged Lights
Optically Controlled: Turns on at night and off during the day.

- IMPORTANT -

- Allow 8 hours of charging before first use
- Angle solar panel to the south to maximize charging
- One year limited warranty for manufacturer defects
- Please call us to return the defective unit

FlexPost - SM™ Product Overview

ANCHORING

CHOICE OF:



CONCRETE



ASPHALT



ADHESIVE



GROUND

Flexible Channelizer

Full 360° of flexibility

Finished Height	Post Diameter
42"	1 7/8"
55"	1 7/8"

- Protects Vehicles from Damage
- Eliminates Damage to Parking Lot Surface
- Quick & Easy Installation
- 1/8" thick impact and UV resistant Acrylic / PVC
- Withstands repeated 35 MPH impacts
- Contains rugged internal steel zinc-coated spring
- Sign Brackets sold separately



Flexible Delineator Paddle

Decals Available:



- Stands 41" tall by 9" wide
- Made of 1/8" thick impact and UV resistant HDPE
- Withstands repeated 35 MPH impacts
- Offers 360° flexibility
- Contains rugged internal steel zinc-coated spring
- Eliminates damage to parking lot surface
- Protects vehicle from unnecessary damage
- Takes minutes to install with no special tools required



* Decals Sold Separately *

Flexible Guide Post

- Eliminates Damage to Parking Lot Surface
- Quick & Easy Installation
- Directs Pedestrian & Vehicle Traffic
- Offers 360° of Flexibility
- 1/8" thick impact and UV resistant Acrylic / PVC
- Withstands repeated 35 MPH impacts
- Contains rugged internal steel zinc-coated spring



www.flexpostinc.com • sales@flexpost.net • 616-928-0829

SM-DP

FlexPost - SM™ Delineator Paddle



29.5" x 7.5" Decals Sold Separately

- 1 Delineator Paddle
- 2 Turn & Lock Base Plate
- 3 Set Screw

4 Anchoring System



CHOICE OF CONCRETE, ASPHALT, ADHESIVE, OR GROUND ANCHORING

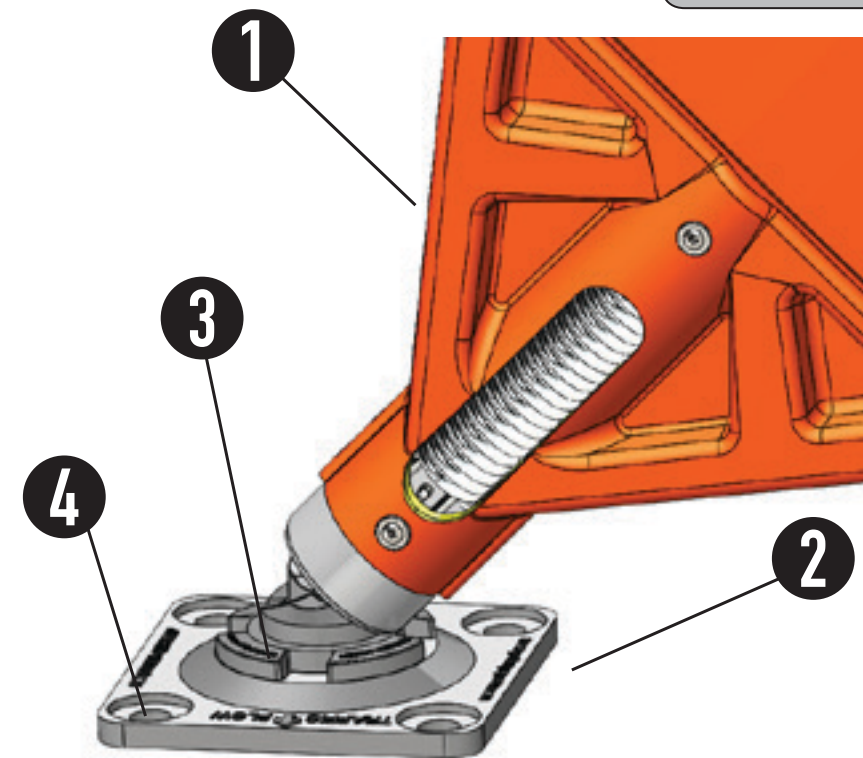

Available Decals:



www.flexpostinc.com • sales@flexpost.net • 616-928-0829

FlexPost - SM™ Channelizer Post

SM-55P



- 1 1 Channelizer Post
- 2 1 Turn & Lock Base Plate
- 3 1 Set Screw

4 Anchoring System



CHOICE OF CONCRETE, ASPHALT,
ADHESIVE, OR GROUND ANCHORING

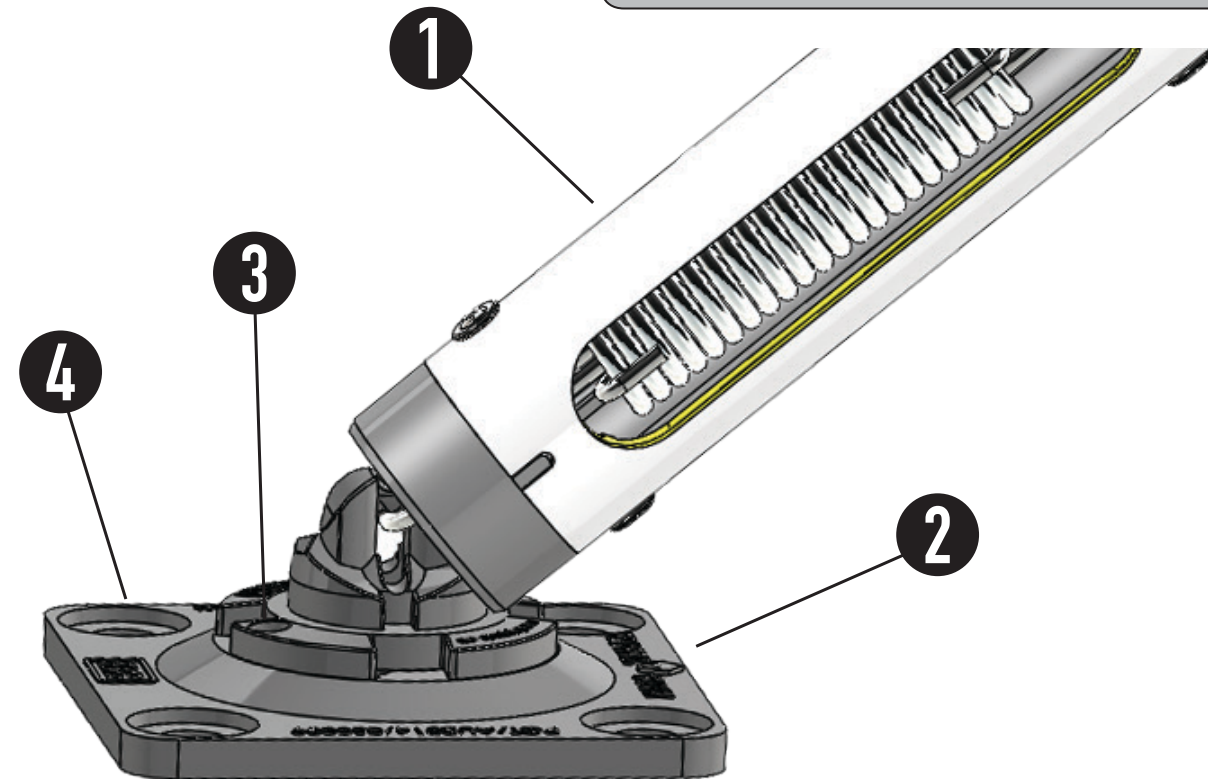

SM-GP

FlexPost - SM™ Guide Post



- 1 1 Guide Post
- 2 1 Turn & Lock Base Plate
- 3 1 Set Screw

4 Anchoring System



CHOICE OF CONCRETE, ASPHALT,
ADHESIVE, OR GROUND ANCHORING

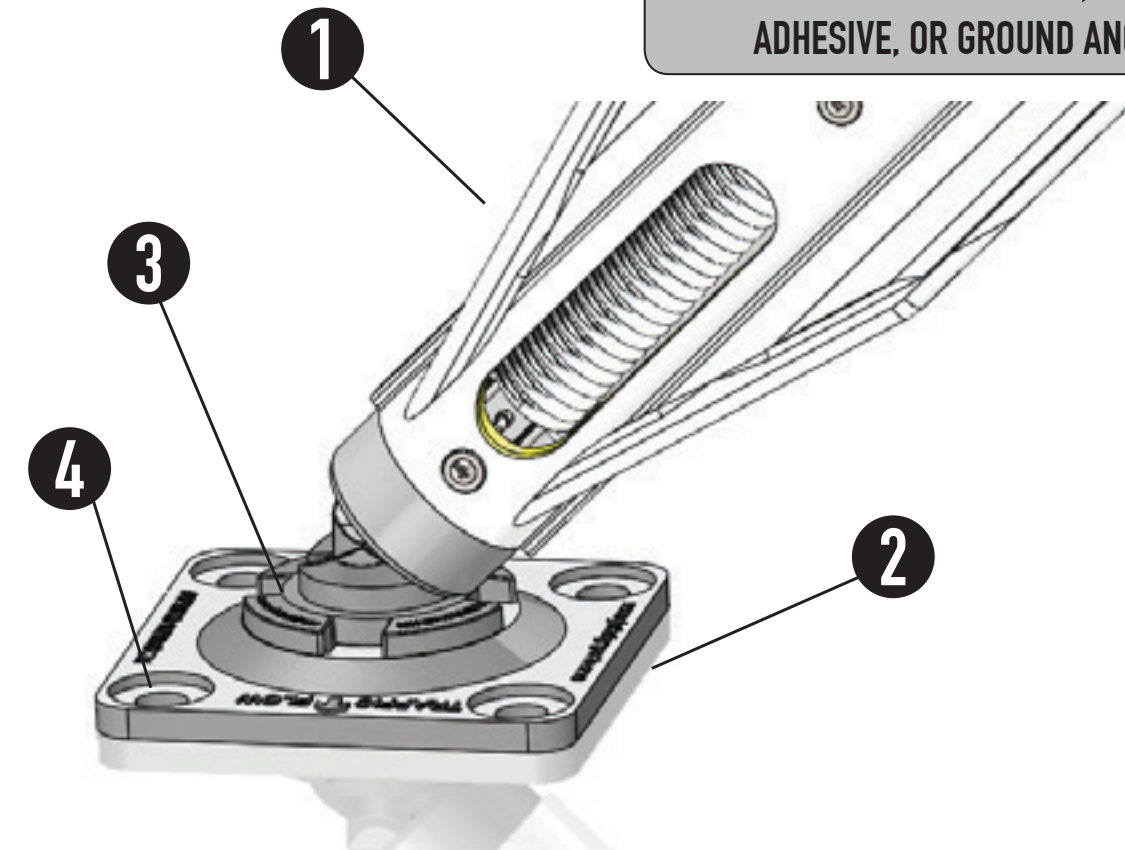

FlexPost® Accessories

ANCHORING SOLUTIONS



CONCRETE:
STD & XL: RE-C
SM: RE-SM-C



ASPHALT:
STD & XL: RE-A
SM: RE-SM-A



GROUND SPIKE:
STD: RE-GS
SM: RE-SM-GS



ADHESIVE: STD & XL: RE-D SM: RE-SM-D

SIGN BRACKETS

DOUBLE SIDED • 2 BRACKETS PER KIT • NO DRILLING REQUIRED

STANDARD: A-SB
XL PRODUCT: A-XL-SB
SM PRODUCT: A-SM-SB



MOBILE BASE

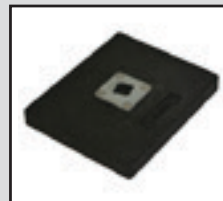

• A-SM-PB18

Available for use with
our SM Product Line



Paddle Sold Separately

REPLACEMENT SPRING KIT

Includes Spring & Hardware

• RE-SK



BASES



STANDARD:
• RE-BP



XL PRODUCT:
• RE-XL-SK



SM PRODUCT:
• A-SM-BP

POST SLEEVES

To Fit 6' Pole: • A-PS6
To Fit 8' Pole: • A-PS8



POST-LITE™

• A-PL-STD
• A-PL-XL



ADA DECAL
• A-ADA



DETENT BRACKET KIT
FOR XL PRODUCT ONLY
• A-XL-DK

SPRING COVER
FOR STANDARD PRODUCT ONLY
• A-SC



FlexPost® Accessories

BOLLARD COVERS

4.5" or 7" Wide 32", 52", or 72" Tall

Bollard Cover & Tape Color Options:

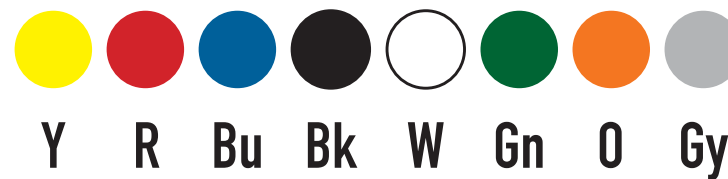

• RE-BC

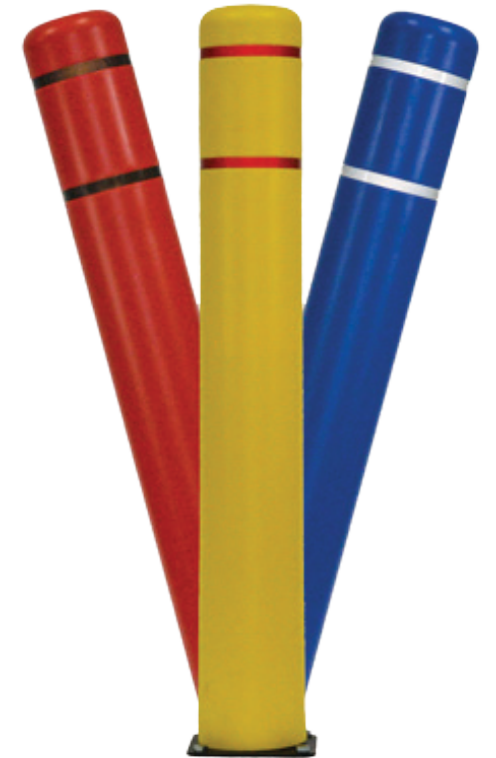

DELINEATOR & BOLLARD DECALS

29.5" x 7.5" decals are for use with a bollard or the SM-Delineator Paddle



A-PED-S



A-PED



A-YBCD



A-YBDD



A-RWDD



FlexPostInc



@Flexpost_Inc



Flexpost-Inc



FlexpostInc

FLEX **POST**[®]



616-928-0829

www.flexpostinc.com • sales@flexpost.net

2236 112th Ave, Suite 80, Holland, MI 49424